

# Quad Multi-Rate Transponder

## Multi-Service Layer 1 transport

### Key benefits:

- Transparent transport of any service between 100Mb/s and 2.7Gb/s
- 4 individual Transponders, which can be combined with the OCU to provide 1+ protection with sub 50 ms switching
- Technology agnostic. Pluggable transceivers enable usage in CWDM as well as DWDM networks
- Multi-functional plug-in unit. Each Transponder can also be used in a regenerator function or to translate between CWDM and DWDM networks
- Low Power Design for low Total Cost of Ownership

The Quad Multi-Rate Transponder (TPQMR) is a powerful part of Transmode's TM-Series platform and a versatile, multipurpose device with four individual Transponders on the same board. Each Transponder is bit rate and protocol transparent from 100Mb/s to 2.7Gb/s. With its wide span of supported traffic formats, the TPQMR is ideal in access and metro networks.

Both client and line interfaces are SFP-based, enabling each interface to use uncolored, CWDM or DWDM plug-in units in any combination. Even electrical SFPs are supported enabling transport of signals such as electrical GbE, STM-1/OC-3 or DVB.

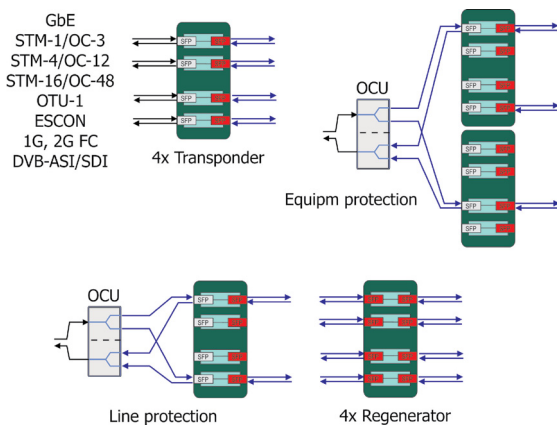

Fig 1. Four operational modes of the TPQMR proving its multi-functional capabilities

Figure 1 shows the different operational modes of the TPQMR. These can be setup independently since each Transponder function is individual. Protection is provided via an optical coupler board (OCU) and the TPQMR units involved in the protection scheme can be placed in the same card cage or in separate chassis in different locations. The latter is established via Protection Control Units (PCU/2P) that provide the fast signaling between chassis that is required for sub 50ms switching.



### Simplified Installation and Commissioning via iWDM™

The TPQMR is based on Transmodes Intelligent WDM (iWDM) concept where the connected client signals are automatically identified. This removes the need for manual configuration.

### Tailored Network Element options

The TPQMR can be mounted in any of the TM-Series chassis options;

- As a self-managed Network Element in a 1U TM-101/102 chassis
- As one of many traffic units in a TM-3000 (10U) or TM-301 (3U) chassis

This enables a tailored setup depending on current and future capacity requirements of the site.

In the TM-101/102 option, the TPQMR initiates the complete Embedded Node Management (ENM) on the on-board micro processor. This enables local management simply by connecting any PC or work station and launching a standard internet browser.

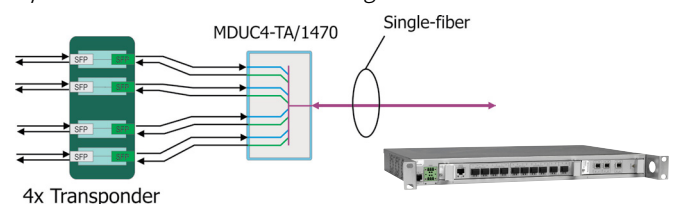

Fig 2. A common TPQMR configuration: 1U Multi-Service NE

Figure 2 shows a 4ch CWDM collector node in a TM-102 chassis, which is typical TPQMR configuration. The four Transponder functions of the TPQMR match perfectly the 4ch CWDM MDU. These CWDM MDU's are available in both single-fiber and fiber-pair configurations.

## Metro to regional network translation

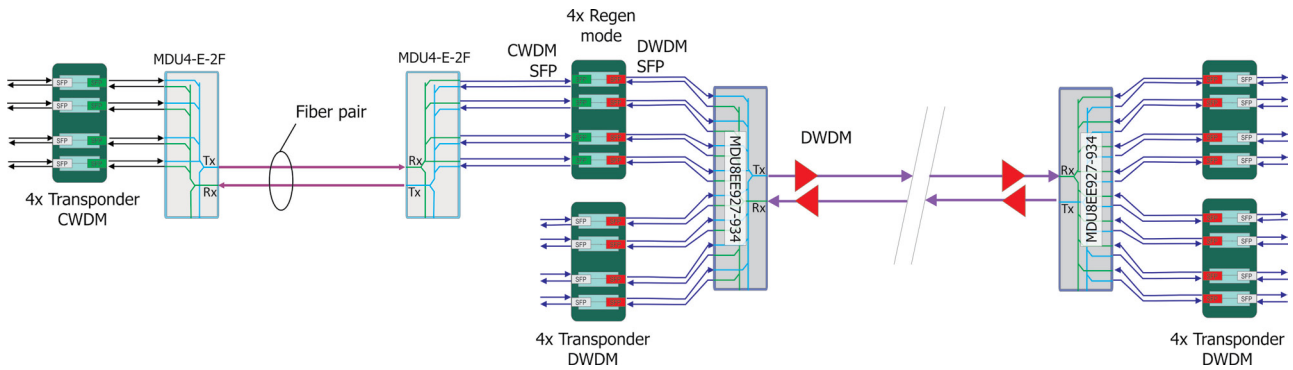

Fig 3. TPQMR used in a CWDM and DWDM network

Figure 3 shows another typical example of how the TPQMR can be used. Here, it is used as a CWDM collector node in an access network. A second TPQMR in the hub node translates from CWDM to an amplified DWDM network by using CWDM SFPs and DWDM SFPs.

### Low Power Design

A fully equipped TPQMR consumes less than 20W. Low power consumption in combination with a small footprint reduces site costs and enables more capacity to be handled at sites with restrictions on power consumption, cooling and space.

## Technical specifications

<b>Supported traffic formats</b>	ESCON STM-16, OC-48, STM-4, OC-12 STM-1, OC-3 (optical, electrical) 1G FC, 2G FC DVB-ASI (dvb270), HDTV (hdtv1485) GbE (optical, electrical) Sync-E (G.8262/Y.1362) FE (optical, electrical) OTU-1
<b>Layer 1 Performance Monitoring</b>	Simplified, based on LOS, LOF Collected every 15min/24h and presented according to G.826 using ES, SES etc
<b>Protection</b>	1+1 Line protection. Non-revertive switching in normal mode , typically <20ms
<b>Power consumption</b>	Max 20W worst case (with all client ports active and using DWDM SPFs)
<b>Misc line interface features</b>	Auto protocol recognition
<b>Interfaces</b>	Client interfaces: SFP-based. Supporting MM, SM @ 1310nm/1550nm, electrical SFPs etc Line interfaces: SFP-based. 40ch DWDM, 8ch CWDM
<b>Latency</b>	<10ns between two Transponder functions
<b>Timing</b>	3R, through-timing

The specifications and information within this document are subject to change without further notice. All statements, information and recommendations are believed to be accurate but are presented without warranty of any kind. Contact Transmode for more details.

www.transmode.com