

Protection Control Unit

Enabling high availability protection

Key benefits:

- Carrier-grade protection between traffic units placed at different locations
- High availability protection selectable on a per unit basis
- Cost efficient protection against total node failure, for example loss of primary power
- Can be mixed with other protection schemes for optimal protection level of transported traffic

The Protection Control Unit (PCU) is part of Transmode's TM-Series platform enabling optimized and cost efficient transport networks based on CWDM/DWDM technology. Optimized for Metro/Access applications.



Redundancy level challenges

Protection between two traffic units within the same card cage of a chassis is normally secure enough since the chassis has redundant power supplies as well as redundant fan units. Since the traffic units are placed in the same card cage, it is easy to provide sub 50ms switching since a direct HW connection can be used to provide the required fast signaling between the units.

However, in special cases this redundancy level is not sufficient. To further enhance the availability figures, the two traffic units must be placed in separate chassis, so that it is possible to place them in separate buildings or even at separate sites.

To enable the Transponders to be placed in separate chassis, the signaling between the units/chassis must be solved in a manner that still can provide carrier-grade switching within 50ms. This rules out a DCN-based solution since this will involve the node Control Unit and SW functionality.

Transmode Protection Control Unit

The Protection Control Unit (PCU) is a special plug-in unit that is placed in the chassis involved in the protection scheme. The PCU is an active, half-height plug-in unit having two SFP ports. This is a new type of unit for the TM-Series. All previous half-sized plug-in units are passive and are placed in the passive slot section in the card cage.

In the TM-3000 card cage up to 10 half-height units can be mounted in the right hand side via the supporting shelf.

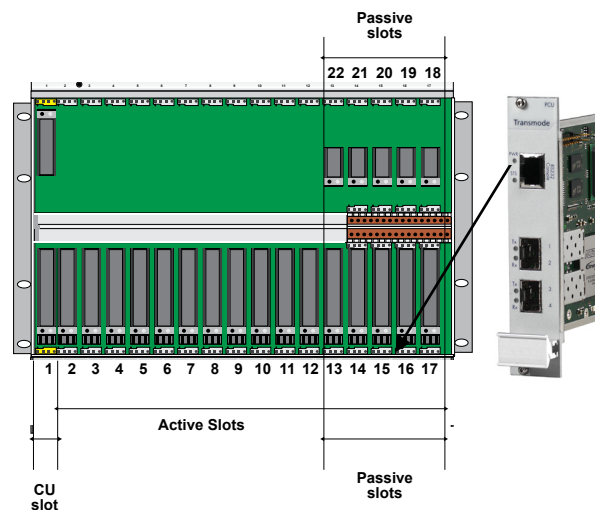

Fig. 1 TM-3000 card cage

The back plane has "active connectors" also in the right section enabling active full-height units to be placed also in this section, given that the supporting shelf is reduced in length. Consequently an active half-height unit can also be inserted here given that it is placed in the lower part of the card cage where the active connectors are placed, i.e. in slots 13 - 17.

Fiber-connection sets distance between chassis

The connection between two PCUs uses an optical fiber pair. The distance is thus limited by the SFP type used. Alternatively the signal can be carried over a single-fiber by connecting the SFP to a single-fiber add/drop filter or use a single-strand SFP. The choice is given by the distance between the PCUs.

A protection setup where the Transponders are placed in separate chassis will use an optical coupler/combiner (OCU) as shown in Figure 2 to separate the client signal onto the two paths. The OCU is a passive unit and can be placed in either of the chassis containing the Transponders, or in a separate chassis (e.g. passive TM-101 chassis) next to the client equipment.

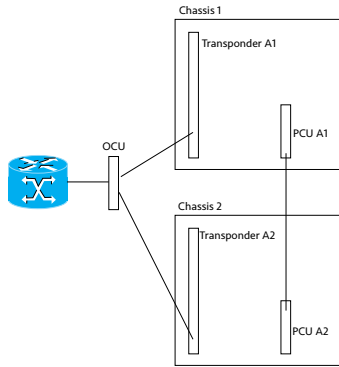

Fig. 2 Principle configuration

One PCU can support protection to all traffic units within a card cage. It is also possible to have a mix of different protection alternatives within a network element, i.e. units without protection, units with protection in same card cage and protection between different card cages using PCUs.

Technical specifications:

Software release 13.0 or later

Line interfaces	2x SFP interfaces, one for future usage Uncolored, CWDM and single-strand SFP's supported Line rate equal to Gigabit Ethernet. Framing is proprietary.
Protection	Equipment protection/sub-network connection protection Sub 50ms Non-revertive Automatic, forced
Power consumption	Max 6W worst case (with one SFP port active), 5W w/o SFPs

Switching criteria's

A protection switching is based on the following criteria:

- Node failure, i.e. power loss of a node. If chassis 1 in the example above has the active Transponder and loses electrical power, a switch will be done to the stand-by Transponder in chassis 2. This is achieved via "Dying Gasp" functionality.
- Board failure, i.e. if the active Transponder fail, a switch will be done to the stand-by Transponder.
- Signal failure, i.e. if the active Transponder loses input line or client signal, or receives a remote fail signal, a switch will be done to the stand-by Transponder.

The switch is non-revertive. A forced toggle of active/stand-by side can be performed.

Alarms will be raised if the PCU-PCU connection is lost or if any of the stand-by connections are lost.

The specifications and information within this document are subject to change without further notice. All statements, information and recommendations are believed to be accurate but are presented without warranty of any kind. Contact Transmode for more details.